

# Reconfigurable Agile Tag Reader Technologies for Combined EAS and RFID Capability

R. Fletcher, O. Omojola, E. Boyden & N. Gershenfeld  
Massachusetts Institute of Technology, Media Laboratory  
Cambridge, MA

**Abstract—In the context of electromagnetic tagging, we present the results from our ongoing work to unify Electronics Article Surveillance (EAS) and Radio-Frequency Identification (RFID) technologies using an open architecture design for tag readers. Two fundamental approaches are presented: microcontroller-based architectures and Field Programmable Gate Array (FPGA) architectures. Using these flexible designs, along with Direct Digital Synthesis of the waveforms, it is possible to create frequency-agile software-reconfigurable hardware which can detect all common varieties of EAS labels and RFID tags. Since much of the functionality can now be performed in software, these new reader technologies can be implemented with little additional cost compared to conventional readers.**

**We present three microcontroller-based design examples of varying complexity ranging in parts cost from \$5/unit to \$500. Ongoing work with an FPGA-based design is also discussed. Finally, we present a common software interface for all tag reader modules and report on approaches to integrate such tag reader hardware into local area networks and to the Internet using 2-way pager technology and dial-up modems.**

## I. INTRODUCTION

The increasing need for object-based information has made electromagnetic identification attractive for many uses, and new varieties of this ID technology appear every year. But although Radio-Frequency Identification (RFID) technology has existed for almost 20 years, there is yet no single data standard for either retail or industrial applications. In addition to the cost per label, the lack of a clear data standard has also been a factor limiting the widespread use of RFID.

For the most part, Electronic Article Surveillance (EAS) labels have existed independently of RFID. However, the benefits of increased automation and real-time inventory data have been incentives for manufacturers to integrate electromagnetic tags with RFID and EAS capabilities into product packaging in the same way that barcode UPC codes are created today. Such a uniform approach to electromagnetic tagging is an attractive concept, but will require significant development in the identification information infrastructure.

While the tag industry is still evolving with many competing technologies, it is prudent to consider the evolution of the detector (tag reader) as well as the label (tag). While retailers and manufacturers struggle to integrate bar code, EAS, and RFID systems in a comprehensively useful manner, much of the burden and risk in committing to a particular form of technology can be alleviated by developing an infrastructure

that is flexible and can seamlessly support multiple tagging technologies. This is the basic concept of an open architecture for electromagnetic tagging.

## II. BASIC REQUIREMENTS

The fundamental function of a tag reader is to transmit energy to a tag, to detect the response of the tag, and to translate the resulting analog signal into meaningful digital data. Although the broad definition of tag reader can include energy propagation in the form of ultrasonics or light, we restrict ourselves here to the case of near-field electromagnetic energy, using either inductive or capacitive coupling.

If we do not include far-field microwave backscatter tags, the standard operating frequency for RFID tags is 125 KHz and 13.56 MHz. A switching network inside the tag produces an amplitude modulation of the excitation signal which can be detected as loading on a single antenna or as a pick-up voltage on a separate receive antenna. To encode information, most RFID systems employ simple AM modulation, but others employ an additional layer of modulation on a subcarrier frequency in the form of FSK or BPSK.

Commercial EAS tagging systems do not encode data and simply detect the presence of a tag. Tags that employ a harmonic means of detection require the tag reader to transmit energy at a low frequency (e.g. 77 Hz) and subsequently scan a higher frequency range (few KHz) to collect a harmonic spectrum. In the resonant mode of detection, the tag reader transmits a RF excitation pulse (at 58 KHz or 8 MHz) then listens for ringing oscillations produced by the tag.

In addition to the tags and frequencies mentioned above, other varieties of tags and sensors have been developed which operate in the frequency range 50 Hz - 50 MHz. For example, access control badges originally developed by Westinghouse require the tag reader to detect embedded resonant structures in the range 5-30 MHz. At MIT, we have developed various forms of electromagnetic material structures to function as ID tags or as a new class of disposable wireless sensors.<sup>1</sup>

In this context, it is possible to outline some ideal fundamental requirements for a general-purpose tag reader:

- The ability to transmit power at a digitally specified frequency over the range of a few Hz to 50 MHz.
- The ability to modulate the transmitted power
- The ability to detect signals at specified frequencies, which may differ from the transmitted frequency.
- Detection frequency resolution of at least 0.1%
- The ability to analyze the detected signals and relay the information to an external network or computer.

Naturally, the specific implementation of these requirements will depend on the specific application, the read range requirement and the targeted cost.

Since it is not practical to build a tuned antenna that could operate over many decades of frequency range, we have assumed that all tag reader antennas would be untuned, with an optimally flat frequency response. For some cases, it is desirable to permit easy substitution of antennas.

### III. DESIGN EXAMPLES AND ANALYSIS

Using the basic set of requirements outlined above we set out to explore several design approaches with respect to different cost targets and varying degrees of complexity.

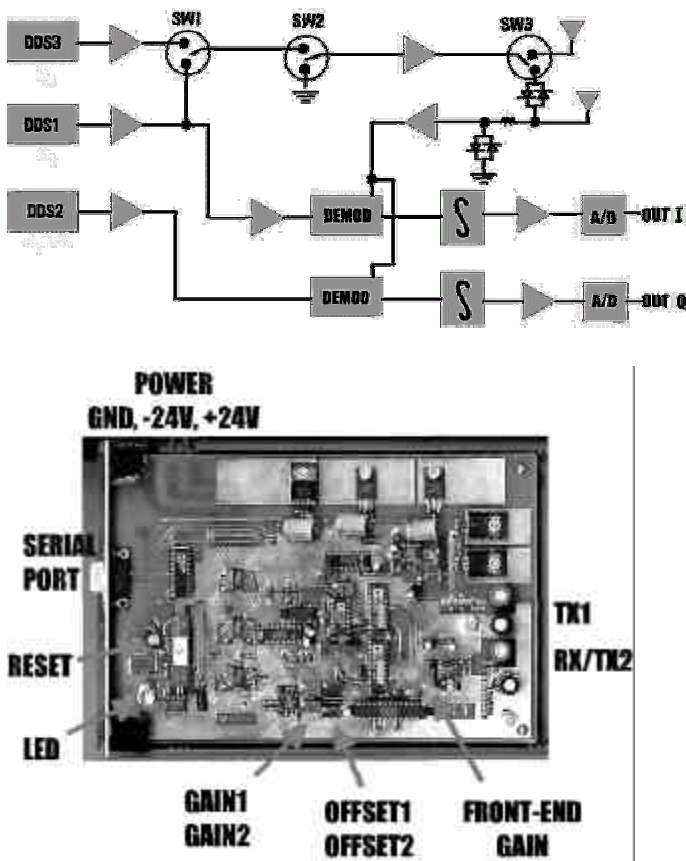

**Fig. 1 Block Diagram and photograph of the wide-band harmonic and resonant tag reader, nicknamed “Sweeper.”**

#### A. Implementation of A Wide-Band Harmonic And Resonant Tag Reader

For approximately \$500 parts cost, we built a tag reader with an operating frequency range of DC-300 KHz that is capable of detecting resonant as well as harmonic signals. The block diagram of this reader is shown in Figure 1. The nickname for this reader is “Sweeper.”

Initial versions of this board employed digitally controlled phase-locked loop (PLL) synthesizers, but the PLL had limited

frequency range and had an inherent settling time when changing frequencies. For these reasons, we converted to direct digital synthesis (DDS) for generating our signals.

Three AD9850 DDS chips with .0251 Hz resolution are employed on the Sweeper board, one for generating the transmitted signal and two for generating the frequencies required for demodulation. The two receiving DDS chips can be set to arbitrary relative phase, but are generally set to a phase difference of 90° apart to generate I- and Q- components of the received signal. Amplitude modulation of the output waveform is accomplished with a solid state switch for simple ON/OFF keying, and frequency and phase modulation can be accomplished in software via the DDS.

Two modes of detection were possible on the Sweeper board: harmonic mode and resonant mode. In harmonic mode, the reader would transmit at a fixed frequency and sweep the frequency of the receiver to collect a spectrum. In resonant mode, the board would sweep both the transmitter and receiver over a range of discrete frequencies, stopping at each frequency to output an RF pulse and listen for the ringing oscillations of any existing resonant structure. The integration times for the detection were software-programmable, so that a variety of both high and low Q structures could be interrogated.

The frequency range of the board was limited by the AD630 synchronous demodulator which is rated to 300 KHz. The solid state switches and push-pull power amplifier stage were limited to approximately 1 MHz.

The received signals were digitized using an LTC1298 12-bit dual-channel serial ADC interfaced to a 20 MHz PIC16C76 microcontroller with 8K of program memory. There was sufficient program memory to implement Taylor series approximation functions in assembly code to translate the I/Q values of the data to magnitude and phase values. The data could then be sent serially to an external host using a variety of user-definable formats. For RFID tags, the output frequency would be held constant and the data demodulation done in software.

This tag reader was designed to operate using either a one or two antenna configuration, settable in software through the use of a solid state switch. Using a supply voltage of +/- 24 V at 800 mA, the Sweeper board could easily power an untuned 15-inch diameter coil and detect resonant EAS tags at a range of 12 inches and harmonic tags at a range of 4 inches. It is expected that read range performance could be improved beyond these values, since we made little effort to optimize the gain and sensitivity of the receiver.

#### B. Implementation of a Mid-Range DDS Tag Reader

Using a target cost of \$50, we set out to build a scaled-down battery-powered version of the previous design to operate in the frequency range 5-40 MHz. This operating range was chosen since the tags at this frequency are relatively cheap, and the transmit antenna at this frequency can be implemented as a single-turn coil integrated onto the printed circuit board.

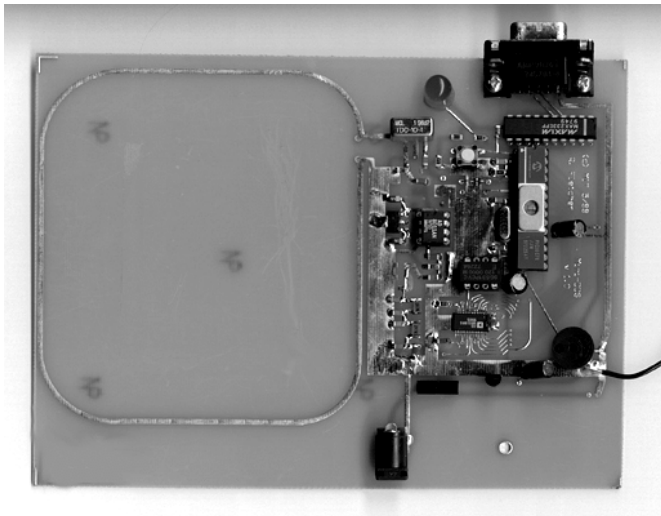
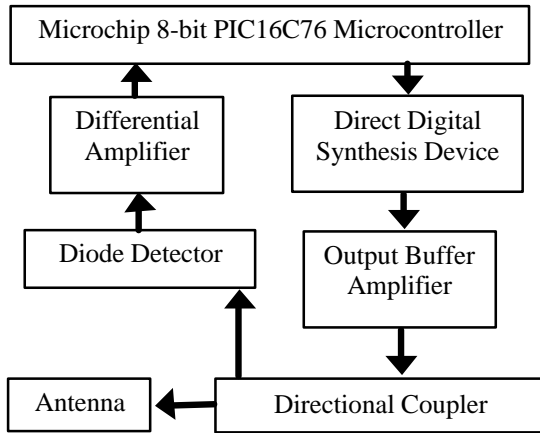

**Fig. 2 Block Diagram and photo of the Mini-DDS reader**

The functional blocks of this tag reader are shown in Figure 2. Frequency generation in this reader is done by a single DDS chip (from which the name “Mini-DDS reader” follows). The output of the DDS is passed through a 4-pole low-pass filter to remove the higher-order alias frequency harmonics. The filtered signal is then amplified using a fast op-amp.

Detection of a resonant tag is accomplished through the use of a 50  $\Omega$  directional coupler configured to measure antenna loading. In this configuration, the untuned single-turn antenna presents an optimally unmatched load and the reflected power is channeled through the directional coupler output. However, when a resonant structure is placed within range of the antenna, the impedance of the resonator dominates the response, and the resulting matched impedance at resonance produces a dip in the reflected power. This method of detection eliminates the need for a broad-band tuned antenna. Also, since the antenna is untuned, the tag reader is quite immune to spurious responses caused by any stray reactance in the environment.

The reflected power output of the directional coupler is fed to a diode detector and the resulting voltage is amplified by an instrumentation amplifier and digitized using a built-in 8-bit A/D module on the microcontroller.

Using a 4-inch diameter reader antenna and a 2-inch diameter EAS tag, a read range of 6 inches was achieved. Reading a 13.56 MHz RFID tag was not attempted, but software demodulation should be possible if the data rate of the tag can be set sufficiently slow.

The tag reader can be powered from a 9-Volt battery, drawing less than 100 mA. If the tag reader needs to communicate with an external device, such as an RS-232 serial port, the additional power needed to drive the interface cable will shorten the battery life accordingly.

### C. Implementation of a Minimal Tag Reader

In the interest of minimizing cost and complexity, we explored a scaled-down version of the previous design with a target cost of \$5 in parts. We refer to this design as the “Zen tag reader.”

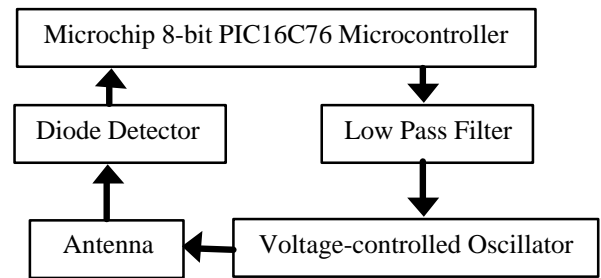

**Fig. 3 Block Diagram of minimal “Zen” tag reader**

Using a design very similar to the Min-DDS reader, it was possible to dramatically reduce the parts cost by simply eliminating the directional coupler, the instrumentation amplifier, and the DDS chip. Considering various approaches to generate a variable frequency, we decided to implement a voltage-controlled oscillator (VCO) using a varactor diode as the tuning element. The control voltage for the VCO was generated in software using a variable duty-cycle square wave which was then fed to a low-pass filter to produce a DC voltage level. The finite control resolution of the duty-cycle and the fundamentally logarithmic response of the low-pass filter limited the frequency resolution to steps of 500 KHz spanning the frequency range 5-15 MHz.

The detection of a resonant tag structure was accomplished by simply sensing a dip in antenna voltage produced by loading at resonance. This approach is reminiscent of the “grid-dip meters” employed in the early 20<sup>th</sup> century. A benefit of using the VCO is the fact that the VCO employs a resonant tank circuit. Therefore, it was possible to integrate the sensing coil as part of the VCO resonator, which resulted in greater sensitivity, thus compensating for the lack of an instrumentation amplifier in the receive path.

Without using a directional coupler, any change in reactance can also produce a frequency-independent change in the antenna voltage. Therefore, the baseline voltage is also a

function of the stray capacitance or inductance near the antenna. This was an important consideration when mounting the reader for a given application.

For battery-powered applications, control over the output frequency was challenging, since a drooping battery voltage would cause some shift in the VCO frequency despite an onboard voltage regulator. Instead of attempting a more complex frequency-control algorithm, we eliminated the need for calibration by implementing a frequency counter using the built-in hardware counter on the PIC microcontroller. By directly measuring the frequency generated by the VCO, closed-loop control of the frequency was then possible.

At a fixed frequency, the performance of the Zen reader was comparable to that of the Mini-DDS reader. However, its limited frequency resolution is insufficient for finding very narrow resonance peaks within a 10 MHz frequency range. Nonetheless, such a reader could be used at a fixed frequency for RFID tags and also as a very coarse swept-frequency reader for detecting a dozen or so tags tuned to specific resonant frequencies. Such a reader would be appropriate for simple applications, such as toys.

#### D. A Versatile Software Radio Implementation of a Tag Reader

Software radio architectures offer great versatility, due to their modular functional decomposition. The basic software radio, whether it is a spectrometer, a monitor for extraterrestrial communication, or a simple tag reader, has three parts: a synthesis stage which converts a digital output signal to analog form, an all-digital stage for performing some computation, and an analog stage for capturing and digitizing an input signal.

The versatility comes from the second, all-digital stage. Progress in digital design can now put an enormous amount of high-speed computing power into a small, cheap package, allowing implementation of complex operations - such as spectral analysis, adaptable filtering, optimizing control, and pattern recognition, often at rates sufficient for real-time processing. Furthermore, several digital designs can be used at varying stages of product development - for example, a complicated FPGA (field programmable gate array) can be used for prototyping a device, a microcontroller can be used for simple testbeds, and an ASIC - perhaps synthesized from the FPGA design itself - can be used for the final product. Because of the abstraction layer between the analog stages and the digital one, computations can even be done remotely - say, on a powerful computer connected to the radio via the Internet.

Physically, a field programmable array (FPGA) is a chip with reconfigurable combinatorial logic, lookup tables, wires, and flipflops in a 2-dimensional array. Elements within the FPGA can be designated as local RAM, others can be treated as input pins, and still others can be combined into registers, accumulators, multiplexers, and other elements. FPGAs can be programmed in many different hardware description languages (HDLs), including the industry-standard ones for specifying digital circuitry, Verilog and VHDL. These hardware description languages allow the same logic (down to the register, wire, and gate level) to be represented independently of the underlying FPGA hardware (with its combinatorial logic

blocks, ratsnests, longlines, pinwires, and other odd constructs). For a tag reader, we can replace a standard DDS chip - which generates a sinusoidal waveform at a specified frequency - with a Verilog description of the DDS, implemented on an FPGA. The Verilog DDS is versatile, allowing one to create a modulation scheme, a shaping function, or a special sweep mode, with just a few lines of code. Adding this functionality to an existing DDS chip can be difficult.

We designed a swept tag reader using a mid-range 950-logic cell, 10,000-gate Xilinx XC4010XL-PC84 FPGA and a 12-MHz clock (as part of an XESS Xilinx Evaluation Board). Eight pins of the FPGA were linked to the digital inputs of an AD7228 8-bit parallel DAC, and 12 pins of the FPGA were linked to the digital outputs of an AD1671 12-bit ADC. The unipolar DAC output was filtered, AC-coupled and fed to a 0.5 Watt push-pull power amplifier stage to power the transmit coil. A receiver coil was placed just under the transmitter coil, and the output of this coil was amplified to fit the 0-5Volt range of the AD1671 ADC.

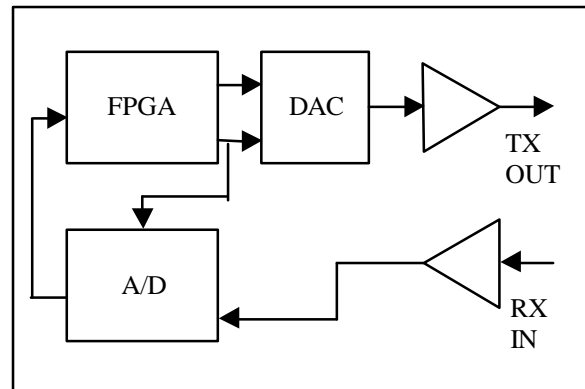

**Fig. 4 Initial implementation of an FPGA-based software- radio tag reader.**

Verilog code for a direct-digital synthesis (DDS) module was written and implemented for the Xilinx FPGA on the XESS board. A DDS contains four simple digital constructs: a clock, a frequency word, a phase accumulator, and an output amplitude. At each clock tick, the phase accumulator is incremented by the value of the frequency word, and the top few bits of the phase accumulator are then converted to a sinusoidal output amplitude via a lookup table. The result is a sinusoidal output with a precisely tunable output frequency, appropriate for performing a network analyzer task such as sweeping through frequencies, or for performing a communication task like FSK modulation. The fundamental block diagram for the FPGA reader is shown in Figure 4.

The FPGA tag reader was able to detect loading from a 58 kHz EAS tag placed inside its small antenna coil, but there was insufficient room on the FPGA to perform the synchronous demodulation needed to extend the read range. Rather than switch to a larger FPGA, we are currently exploring simple ways to make more efficient use of our existing FPGA chip. Some of these options include:

- placing the phase-to-amplitude lookup table in external DRAM, SRAM, or ROM/EEPROM

- storing only one quadrant of the sinewave, from  $q = 0$  to  $p/2$ , and using a little bit of logic to compute amplitudes in the other three quadrants
- doing some of the computation in a general purpose microcontroller, DSP, or computer attached to the FPGA, relegating the FPGA mainly to the realms of fast digital control, interfacing, and reactive performance.

#### IV. CONTROL INTERFACE MODEL

Coming out of the work we described in Section III above, we discovered that certain functionality was common to all the tag readers. For example, in all the tag readers described, there is the ability to sweep over a part of the tag reader's excitation frequency range with variable resolution; as a result there exist commands to set the start frequency, the stop frequency, and the frequency step size. Defaults are set during the power-up cycle of the microcontroller; however, in the course of the tag reader's use there is almost always a need to change them. In a similar fashion, there is other functionality that requires external control, and thus we were drawn to the idea of a standard tag reader interface. We developed a standard set of possible control commands and associated byte sequences that an external agent controlling the tag reader would need to be able to control and communicate with a given tag reader.

A standard software interface simplifies the development of subsequent tag readers by providing a common command set, a subset of which could be implemented in any particular tag reader, depending on the capabilities of its hardware. Separating the design of the tag reader's control structure from the hardware implementation allows us to develop a single robust control program (for a workstation) that would be able to control any tag reader and monitor its data visually. This approach has proved useful as we have developed applications that require multiple tag readers connected to a network.

Command	Sweeper	Mini-DDS	Zen
Set Start Frequency	X	X	X
Set Stop Frequency	X	X	X
Set Step Frequency	X	X	X
Set Single Frequency	X	X	X
Set Detection Threshold	X	X	X
Output data stream	X	X	X
Run calibration routines	X	X	X
Retrieves internal state	X	X	X
Restart sweep	X	X	X
Enable onboard output channel			X
Harmonic Detection	X		
Disable Transmit Stage	X	X	
CW Frequency detection	X		
Accept External Frequency Commands	X	X	X

**Table 1 A brief list of some of the common control commands implemented for various tag readers.**

#### V. INFRASTRUCTURE DEVELOPMENTS AND ANALYSIS

As tag readers become cheaper and more ubiquitous, there is an increasing need to pay attention to the infrastructure necessary to transfer, interpret, and store all the generated information. If we consider a future home, office, retail, or manufacturing environment, it is necessary to find a convenient and efficient way to form networks of such devices and perhaps even to connect them to the Internet.

For most tagging applications, a local area network is desirable. Instead of developing our own proprietary protocol to link tag readers together, we decided to make our tagreaders compatible with standard Ethernet networks employing the TCP/IP protocol. To do so, we used a small 2 in. X 3 in. Ethernet adapter developed in our laboratory. This plug-in adapter converts RS-232 serial data at 110 Kbs to TCP/IP data packets. For a prototype installation used at the Museum of Modern Art in New York City during the summer of 1999, we installed eight tag readers embedded beneath a table and connected to the local area network. On the Ethernet network, a particular data port number identifies each tag reader, and the tag readers constantly output their data on this port. Any interested listener on the network could select a given port and access all the data output by one or more of the tag readers. This allowed multiple workstations connected to the network to monitor any tag reader data in real-time.

For simple Internet access, we have implemented a dial-up modem protocol as a subroutine in our tag reader firmware. This enables the use of an inexpensive external modem as a means of connecting to the Internet. As an example, we have demonstrated a tag reader that can periodically dial the local ISP, establish a connection, and transmit its data files via e-mail to a subscriber.

For portable applications and remote wireless connectivity, we are developing the use of two-way pager technology for tag readers. In regions where pager networks are not accessible, our group has also developed a small satellite transmitter interface for communicating directly with a low-earth orbiting satellite system such as Argos or Orbcom.

#### VI. SUMMARY AND FUTURE DEVELOPMENTS

We have presented the concept of an open architecture for electromagnetic tagging. The hardware architecture is open in the sense that its functionality can be reconfigured in software via a network to meet the specific needs of a particular application and tag technology. Implementation of such a general purpose reader requires frequency agility and fast logic capable of performing real-time frequency control, transmit modulation, and receiver software demodulation. Finally, we presented the concept of a common software interface, which enables computers on a network to control and communicate with multiple tag readers over the network.

<sup>1</sup> Fletcher, Rose, Levitan, Gershenfeld; *Application of Smart Materials to Wireless ID Tags and Remote Sensors*; Materials for Smart Systems II; Proceedings of 1996 Fall Meeting, Materials Research Society.